

ECE 3113

S-PARAMETER RECORDING OF AN RF TRANSISTOR IN ADS

Objective

In this project you are asked to find the S-parameters of properly biased active device. Figure 1 depicts the ADS setup for the simplest bias network previously discussed.

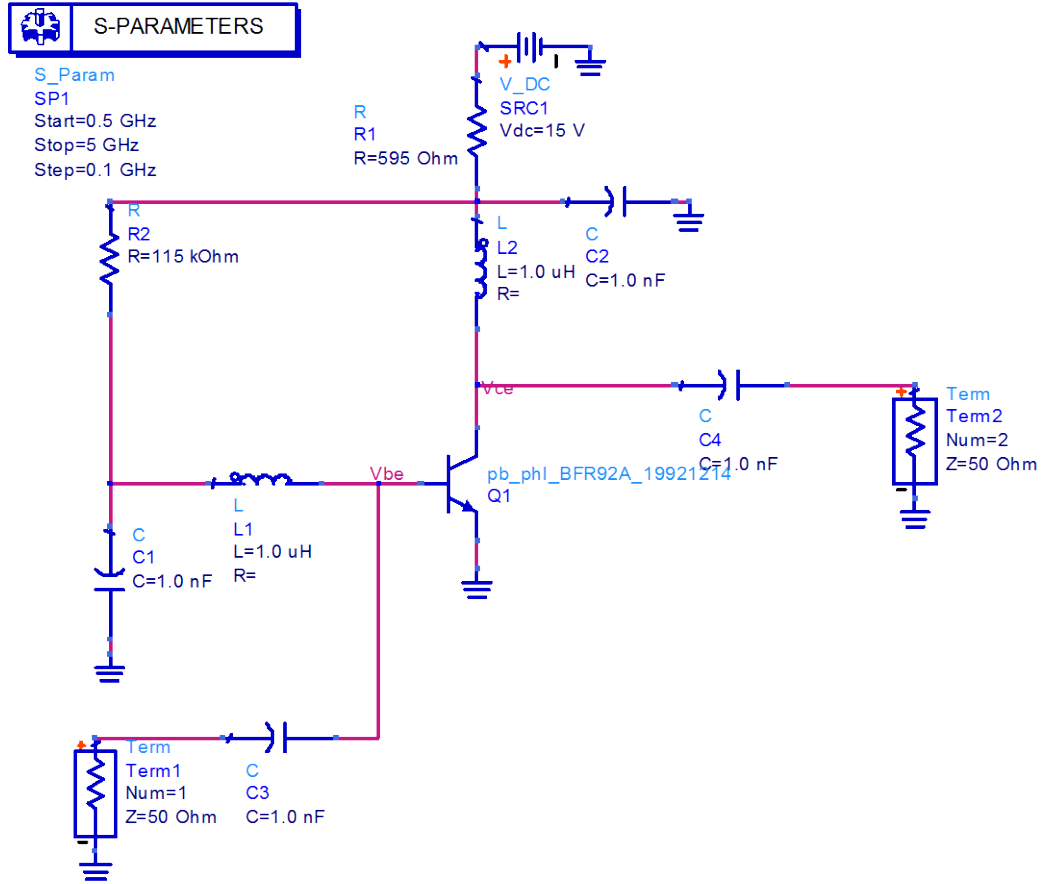

Figure 1. S-parameter setup for npn RF BJT based on a passive two resistor network.

As you can see, Term 1 and Term 2 are ADS-specific input/output ports needed in conjunction with the S-Parameters controller in the left-hand corner. You can “push-in” the controller and set the start (here: 0.5GHz), stop (here: 5GHz), and step size (here: 0.1GHz).

Approach

1. For the previously selected device BFR92A from the ADS library create a table that plots all four S-parameters as a function of frequency ranging from 1GHz to 5GHz in increments of 500MHz.

freq	S(2,2)	S(2,1)	S(1,2)	S(1,1)
1.000 GHz	0.501 / -16.677	3.870 / 80.179	0.110 / 76.339	0.081 / -130.456
1.500 GHz	0.470 / -20.034	2.692 / 68.110	0.167 / 74.517	0.066 / 178.307
2.000 GHz	0.433 / -24.914	2.123 / 57.797	0.229 / 71.009	0.091 / 148.000
2.500 GHz	0.382 / -30.944	1.800 / 48.332	0.297 / 66.227	0.127 / 135.287
3.000 GHz	0.316 / -38.117	1.596 / 39.341	0.370 / 60.269	0.171 / 128.955
3.500 GHz	0.232 / -46.640	1.457 / 30.607	0.445 / 53.195	0.225 / 124.489
4.000 GHz	0.130 / -57.558	1.352 / 22.019	0.518 / 45.136	0.288 / 119.961
4.500 GHz	0.018 / -104.451	1.263 / 13.585	0.583 / 36.341	0.360 / 114.638
5.000 GHz	0.111 / 115.668	1.180 / 5.435	0.634 / 27.178	0.436 / 108.488

2. Plot the $S(1,1)$ and $S(2,2)$ parameters in separate Smith-Charts and use markers at the 2GHz and 3GHz frequency points.

m1
 freq=2.000GHz
 $S(1,1)=0.091 / 148.000$
 impedance = $Z_0 * (0.853 + j0.083)$

m5
 freq=3.000GHz
 $S(1,1)=0.171 / 128.955$
 impedance = $Z_0 * (0.780 + j0.214)$

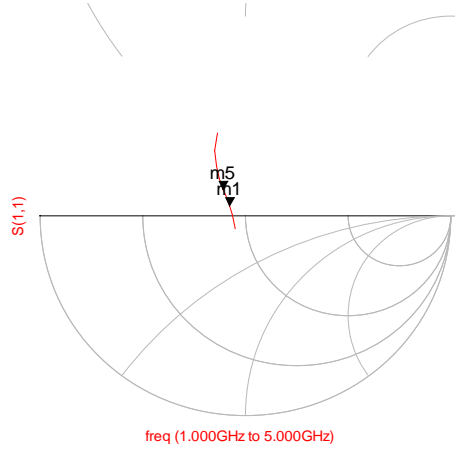

m2
 freq=2.000GHz
 $S(2,2)=0.433 / -24.914$
 impedance = $Z_0 * (2.020 - j0.906)$

m6
 freq=3.000GHz
 $S(2,2)=0.316 / -38.117$
 impedance = $Z_0 * (1.494 - j0.647)$

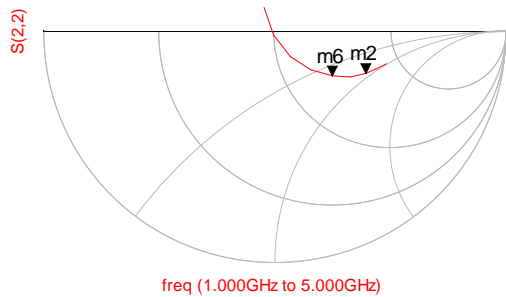

3. Plot the $S(1,2)$ and $S(2,1)$ parameters in separate Polar Forms and use markers at the 2GHz and 3GHz frequency points.

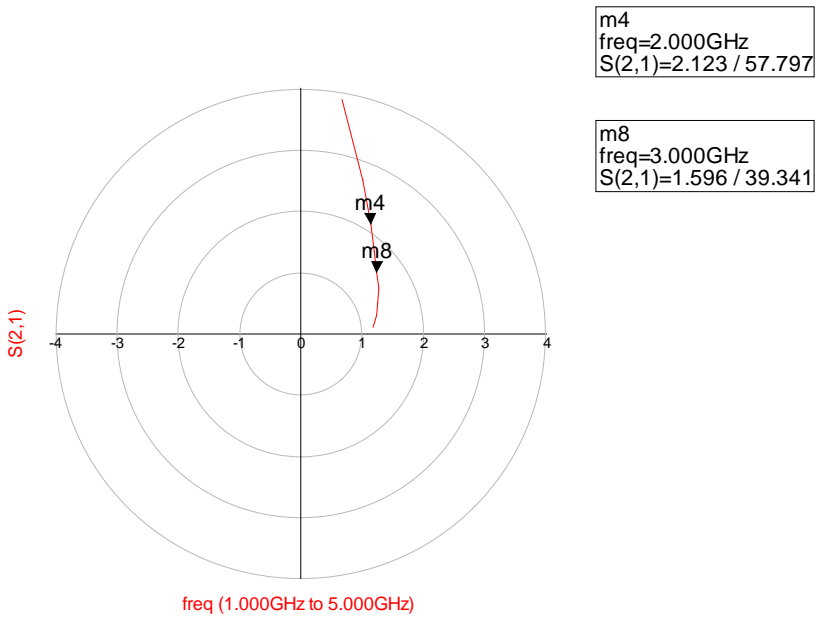
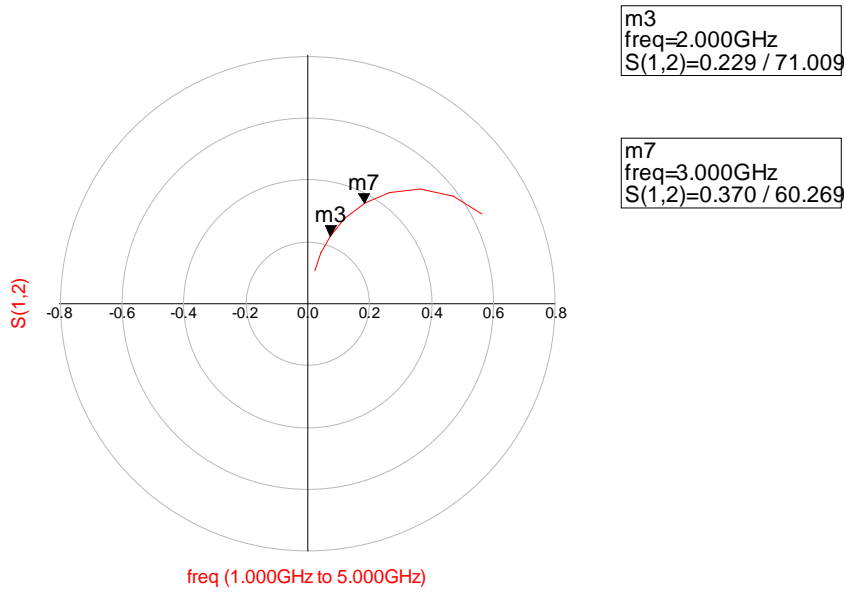

4. stability condition

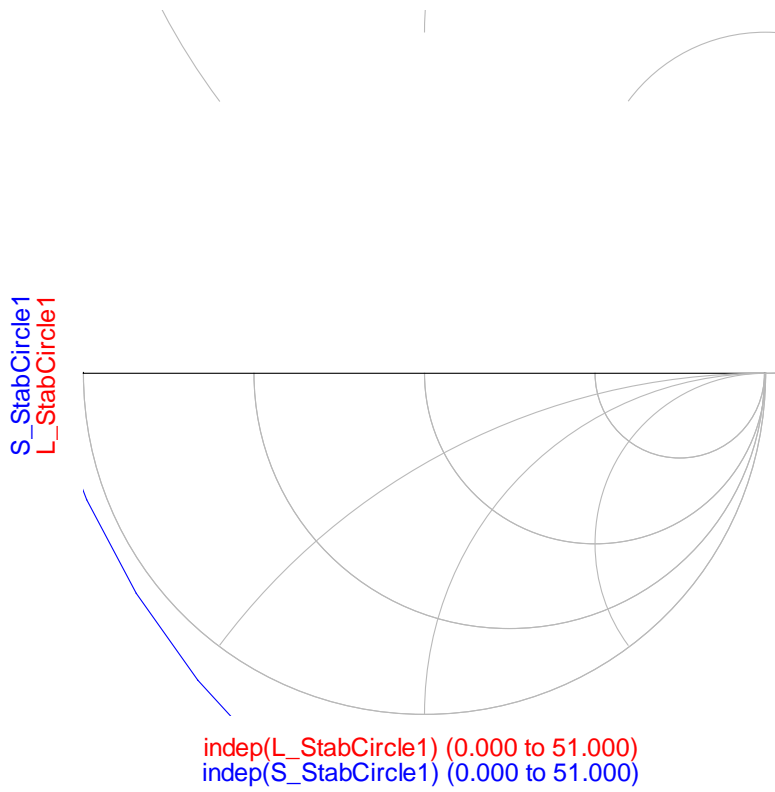

freq	delta	StabFact1
2.000 GHz	0.447 / -50.692	1.033